

HYDRA KOOL



**PULL OUT
CONDENSING UNIT
ON SELF CONTAINED**



**PULL OUT EVAP PAN
FOR EASY CLEANING
ON SELF CONTAINED**



**DIGITAL CONTROLLER
WITH HIGH HEAD ALARM
ON SELF CONTAINED**

CURVED GLASS DELI CASE

**MEDIUM TEMPERATURE
TILT OUT CURVED
TEMPERED FRONT GLASS
REAR TEMPERED
SLIDING DOORS
DESIGNED FOR FRESH MEAT**

MODELS

KFM - CG - (40,50,60,80,100,120) - S

KFM - CG - (40,50,60,80,100,120) - R



Intertek



Intertek

**REMOTE AND SELF CONTAINED
404A REF - FORCED AIR REFRIGERATION**



Tel.: 514.737.9701 / Toll Free: 888.275.4538

Fax: 514.342.3854 / Toll Free: 877.453.8832

sales@mvpgroupcorp.com

www.mvpgroupcorp.com



CURVED GLASS HYDRA KOOL DELI CASE

SELF CONTAINED	MODELS	O.A. LENGTH INCHES	CASE TEMP	ELECTRICAL - 115 VOLTS					WEIGHT LBS
				COMPRESSOR		LIGHTS AND FANS	EVAP PAN	TOTAL AMPS	
				F.L.A.	L.R.A.				
	KFM-CG-40-S	40-3/8	32/40 F	10.5	40	1.0	3.3	14.8	333
	KFM-CG-50-S	52-1/8	32/40 F	8.4	41	1.1	3.3	12.7	377
	KFM-CG-60-S	60	32/40 F	8.4	41	1.3	3.3	13.1	428
	KFM-CG-80-S	77-1/2	32/40 F	9.9	49	2.0	3.3	15.2	531
	KFM-CG-100-S	101-1/8	32/40 F	12.9	64	2.2	3.3	18.4	659
	KFM-CG-120-S	117	32/40 F	12.9	64	2.5	3.3	18.8	787

REMOTE	MODELS	O.A. LENGTH INCHES	CASE TEMP	115	B.T.U.	WEIGHT LBS
				VOLTS		
				TOTAL		
				AMPS		
	KFM-CG-40-R	40-3/8	32/40 F	0.5	2194	265
	KFM-CG-50-R	52-1/8	32/40 F	0.6	2859	322
	KFM-CG-60-R	60	32/40 F	0.9	3260	373
	KFM-CG-80-R	77-1/2	32/40 F	1.1	4209	498
	KFM-CG-100-R	101-1/8	32/40 F	1.3	4845	604
	KFM-CG-120-R	117	32/40 F	1.6	6357	721

THESE CASES ARE DESIGNED TO OPERATE USING R404A REFRIGERANT

B.T.U.'S CALCULATED AT +14° F EVAP AND 90° F AMBIENT

CASES ENGINEERED TO OPERATE AT 75° F AND 55% RH

** ON REMOTE CASES - IF NO FLOOR DRAIN IS PROVIDED - AN EVAPORATIVE DRAIN PAN MUST BE ORDERED
ADD 3.3 AMPS WHEN USING A PAN

O.A. DIMENSIONS INCLUDE (2) ENDS - EACH 1-1/2"

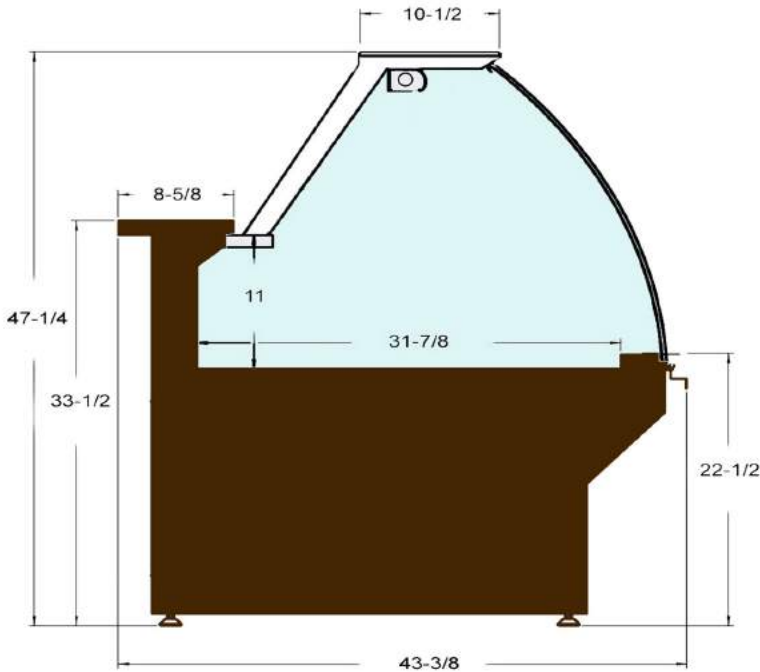

MOUNTING

STANDARD



ADJUSTABLE FEET

OPTIONAL



ADJUSTABLE LEGS

OPTIONAL



CASTERS

STANDARD FEATURES

- INSULATION - INJECTED FOAM
- INTERIOR - STAINLESS STEEL
- EXTERIOR - PVC COATED STEEL-SILVER
- ENDS-FOAMED BLACK POLYSTYRENE
- TILT- FORWARD TEMPERED FRONT GLASS
- CORD AND PLUG
- CASES ARE MULTIPLEXIBLE
- LED LIGHTING IN CANOPY
- REMOVABLE REAR TEMPERED GLASS SLIDING DOORS
- DEFROST AND TEMPERATURE REGULATED BY A DIGITAL CONTROLLER
- REMOVABLE EVAPORATIVE PAN FOR EASY CLEANING ON S/C ONLY
- PULL-OUT CONDENSING UNIT -ON S/C ONLY
- ANTI-CONDENSATE SYSTEM FOR FRONT GLASS
- ADJUSTABLE FEET
- ETL LISTED TO UL471 AND SANITATION CLASSIFIED TO NSF7

OPTIONAL FEATURES

- LIFT UP FRONT GLASS
- CASTERS - ADD 4-3/8" TO HEIGHT
- ADJUSTABLE STAINLESS STEEL LEGS- FROM 5-1/8" TO 7-5/8"
- OTHER COLORS AVAILABLE
- STAINLESS STEEL EXTERIOR
- EVAPORATIVE PAN FOR REMOTE CASES
- WHITE APOXY BI-LEVEL WIRE RACKS
- SCALE STAND WITH RECEPTACLE
- CUTTING BOARD
- (2) OR (3) LEVEL STEP SHAM
- KNIFE SUPPORT

WARRANTY

ONE YEAR PARTS AND LABOR WITH FOUR ADDITIONAL YEARS COMPRESSOR (PARTS ONLY)