



DCSC24

COMMERCIAL STEAM CABINET



DCSC24



Technical Specifications

Gas Pressure	Natural Gas: 4 in. w.c. Propane: 10 in. w.c.
Nozzle Size	Natural Gas: #32 Orifice Propane: #48 Orifice
Available Gases	Natural Gas / Propane

Features & Benefits

- Independent chambers prevent flavor mixing and ensure consistent results.
- Three-tier capacity supports high-volume kitchen operations.
- Efficient natural-draft burner for fast heating and high energy performance.
- Stable ignition with safety protection for reliable operation.
- Dual-valve system enables flexible flame adjustment.
- Tight door sealing ensures better heat and moisture retention.
- Durable, hygienic, and easy to clean.
Safe to touch and ideal for high-frequency operation.
- Enhanced stability for heavy-duty kitchen use.



Los Angeles | San Francisco | Dallas | Houston |
Florida | Chicago | New Jersey | Colorado | Georgia

1-800-931-8628

info@dukersusa.com

www.DukersUSA.com

COMMERCIAL STEAM CABINET

DCSC24

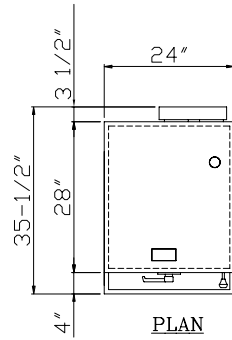

Layer Dimensions	
Working Area (Upper Layer)	14 1/2 × 23 1/4 × 8 3/4
Working Area (Middle Layer)	14 1/2 × 23 1/4 × 8 3/4
Working Area (Lower Layer)	14 1/2 × 23 1/4 × 15 3/4

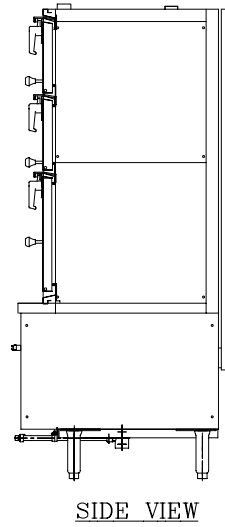
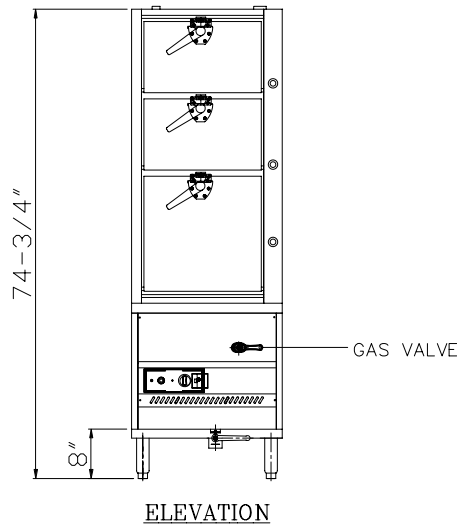

COMMERCIAL STEAM CABINET

Model	External Dimensions (inches)			Packing Carton (inches)			Burner	Single Burner Power	Total Power	Net Weight	Gross Weight	40HQ Container Certification
	W	D	H	W	D	H						
DCSC24	24	35 1/2	74 3/4	28	39 3/4	82 1/4	2	45000BTU/H	90000 BTU/H	202	247	36



Los Angeles | San Francisco | Dallas | Houston |
Florida | Chicago | New Jersey | Colorado | Georgia

1-800-931-8628
info@dukersusa.com
www.DukersUSA.com