



DUKERS

Quality Commercial Refrigeration



CHEF BASE MODEL DCB72



TECHNICAL SPECIFICATIONS

- Voltage/Frequency 115V/60HZ
- Refrigerant R290/2.64oz
- Type of Defrost Automatic
- Interior Material 304/201 Stainless Steel
- Exterior Material 304/201 Stainless Steel
- Total Current 2.549A
- Climatic Category 4-5
- Nema Config. NEMA5-15P
- Compressor Power (HP) 1/5

PRODUCT FEATURES

- Digital temperature control features a digital display to make monitoring interior temperatures a breeze. This unit also comes with an auto-defrost function.
- Foamed-in-place insulation keeps the interior cold and adds structural strength.
- Stainless steel Interior with rounded corner for easy cleaning. Meet and exceed sanitation standards.
- Durable and high weight bearing rails for drawers. 3 divider bars per drawer.
- Heavy-duty 4" casters with brakes are included providing the unit with convenient mobility, making cleaning and servicing a breeze! Just roll the unit away from the wall.
- Ergonomic and modern recess door handles.
- Removable Drawer Gaskets, each drawer gasket is removable for easy cleaning and maintenance.

HIGH QUALITY STAINLESS STEEL & ROBUST DESIGN

TEMPERATURE RANGE (F°)	EXTERNAL DIMENSION WDXH (INCHES)	PACKAGING DIMENSION WDXH (INCHES)	PRODUCT NET WEIGHT	DRAWERS	40 HQ CONTAINER CERTIFICATION
33~38°F	72x32 1/4"x26 5/8"	73 5/8"x34 1/4"x29 1/8"	308 lbs	4	39



Los Angeles | San Francisco | Dallas
Houston | Florida | Chicago | New Jersey

1-800-931-8628

@ info@dukersusa.com

www.DukersUSA.com

DETAILS & SPECIFICATIONS

CHEF BASE

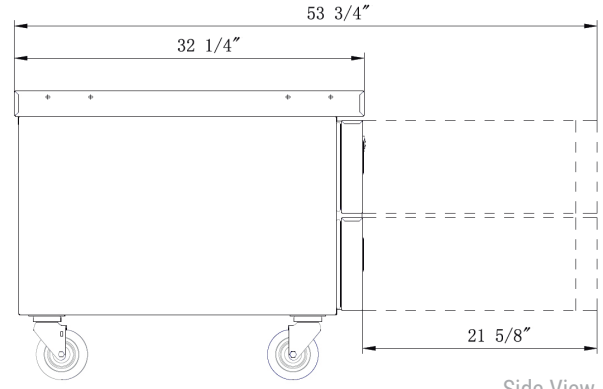
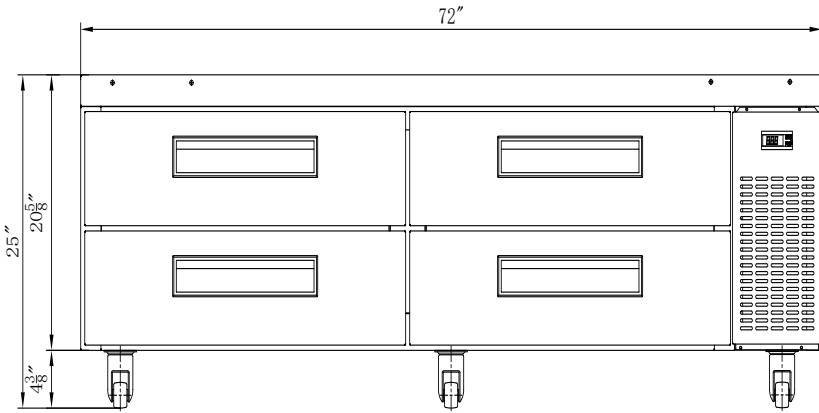

Side View

MODEL DCB72

Rated Voltage	115V
Rated Frequency	60Hz
Total Input Power	255W
Total Current	2.549A
Climatic Category	4-5
Protection Type	I
Design Pressure High Side	300 PIG
Design Pressure Low Side	150 PIG
Insulation Blowing Gas	C-Pentane
Net Weight	308 lbs
Nema Config.	NEMA5-15P
Temperature Range	33~38°F
Heating Power	288W
40 HQ Container Certification	39
Refrigerant	R290/2.64oz
1/6 Pan Count	24
Compressor Power (HP)	1/5

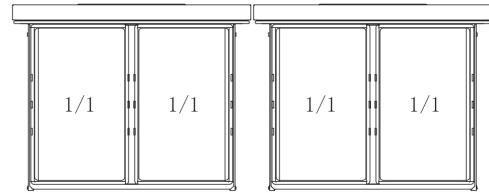

FULL PANS

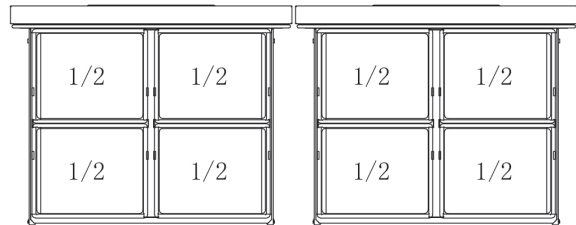

HALF PANS

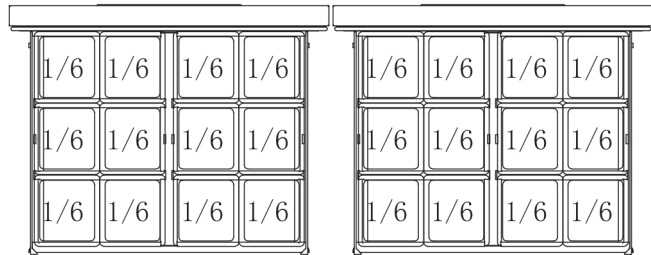

SIXTH PANS

Pan Layout



Los Angeles | San Francisco | Dallas
Houston | Florida | Chicago | New Jersey

1-800-931-8628

@ info@dukersusa.com

www.DukersUSA.com