



Item: \_\_\_\_\_

Quantity: \_\_\_\_\_

Project: \_\_\_\_\_

## Royal Series

Models:  RFT-75



RFT-75 with optional casters

Gas Type:  Natural  LP

Elevation (if above 2000 ft.): \_\_\_\_\_

### Options and Accessories

- Stainless steel tank cover
- Stainless steel side splash guard
- Stainless steel joiner strip
- 48" quick disconnect and restraining cable
- 5" swivel casters (set of four - 2 locking)

### Standard Features

- All stainless steel front and sides
- 75 lb capacity stainless steel tank assembly
- 18" x 18" frying area
- Cast iron burners rated at 38,000 BTU/hr each
- Millivolt control system with 100% safety shut off
- Thermostatic control with 200°-400° F range
- Two fry baskets with plastic coated handles for ease of handling
- 1¼" full port drain valve
- 6" high adjustable heavy duty legs
- One year limited warranty, parts and labor
- Five year limited (prorated) warranty on S/S tank



# 75 lb. Deep Fat Fryer

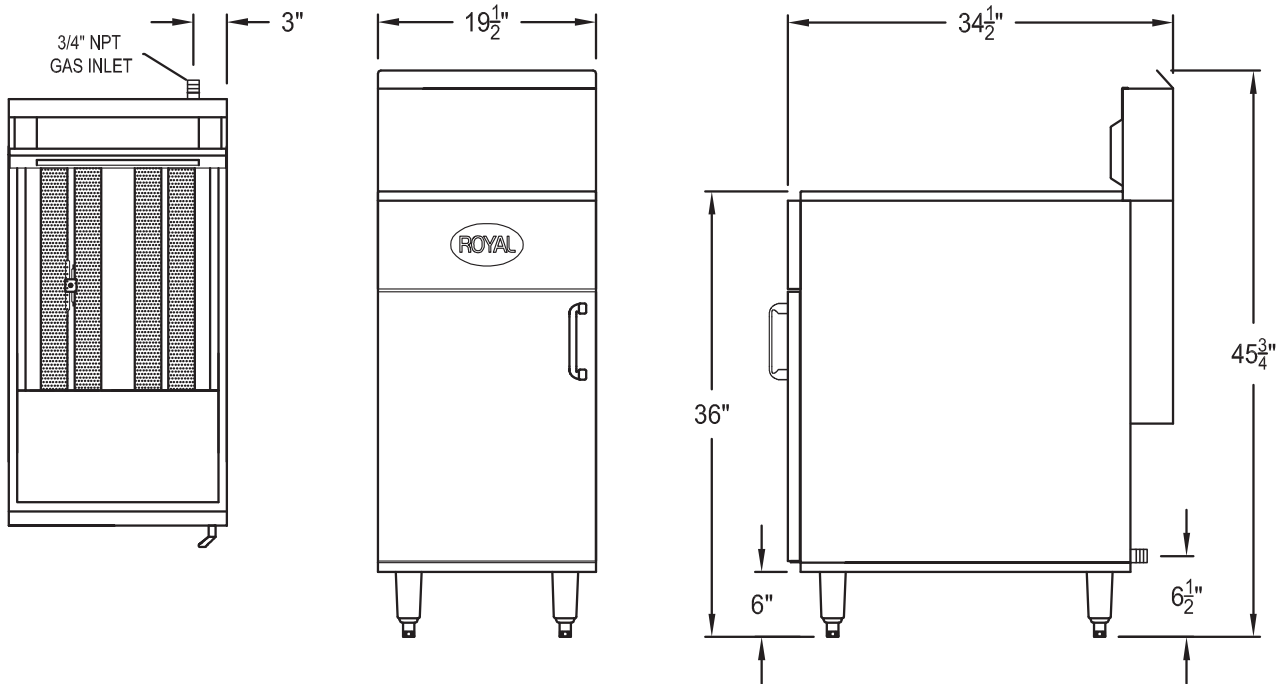

Model Number	Cooking Area	Number of Burners	Total BTU	Ship Weight
RFT-75	18" x 18"	4	152,000	210 lbs.

**Notes:**

- Burner rated at 38,000 BTU/hr

**Gas Connection:**

3/4" NPT on the left hand rear of the appliance.  
No external pressure regulator required.

**Gas Pressure:**

4" W.C.	Natural Gas
11" W.C.	Propane

**Clearances:**

	Combustible	Non-Combustible
Rear	6"	0"
Sides	6"	0"

Specify type of gas and altitude, if over 2,000 feet, when ordering.

Due to continuing product development to ensure best possible performance, these specifications are subject to change without prior notification.

**Royal Range of California**  
 3245 Corridor Dr. • Eastvale, CA 91752 • (800) 769-2414 • (951) 360-1600  
 Fax: (951) 360-7500 • www.royalranges.com • sales@royalranges.com