



Item: \_\_\_\_\_

Quantity: \_\_\_\_\_

Project: \_\_\_\_\_

**Teppanyaki Griddle**

## Royal Series

Models:  RTY-24     RTY-36     RTY-48     RTY-60



RTY-36

Gas Type:  Natural     LP

Elevation (if above 2000 ft.): \_\_\_\_\_

### Standard Features

- Large 1½ gallon capacity stainless steel grease can
- Stainless steel front, ledge and sides
- Round cast iron burner rated at 33,000 BTU/hr creates a center hot spot required for teppanyaki cooking
- 3/4" thick griddle plate with polished cooking surface
- Full 24" deep plate provides ample cooking space
- Adjustable gas valve with standing pilot
- Stainless steel grease trough
- Stainless steel tubing for burners and pilots
- Warranty applies to commercial applications only

### Options and Accessories

- Spacer frame on three sides
- Safety pilot control system
- Plate splash on three sides
- 1" thick griddle plate
- Extra burner



**LIMITED WARRANTY, TWO YEAR PARTS AND ONE YEAR LABOR**

# Teppanyaki Griddle

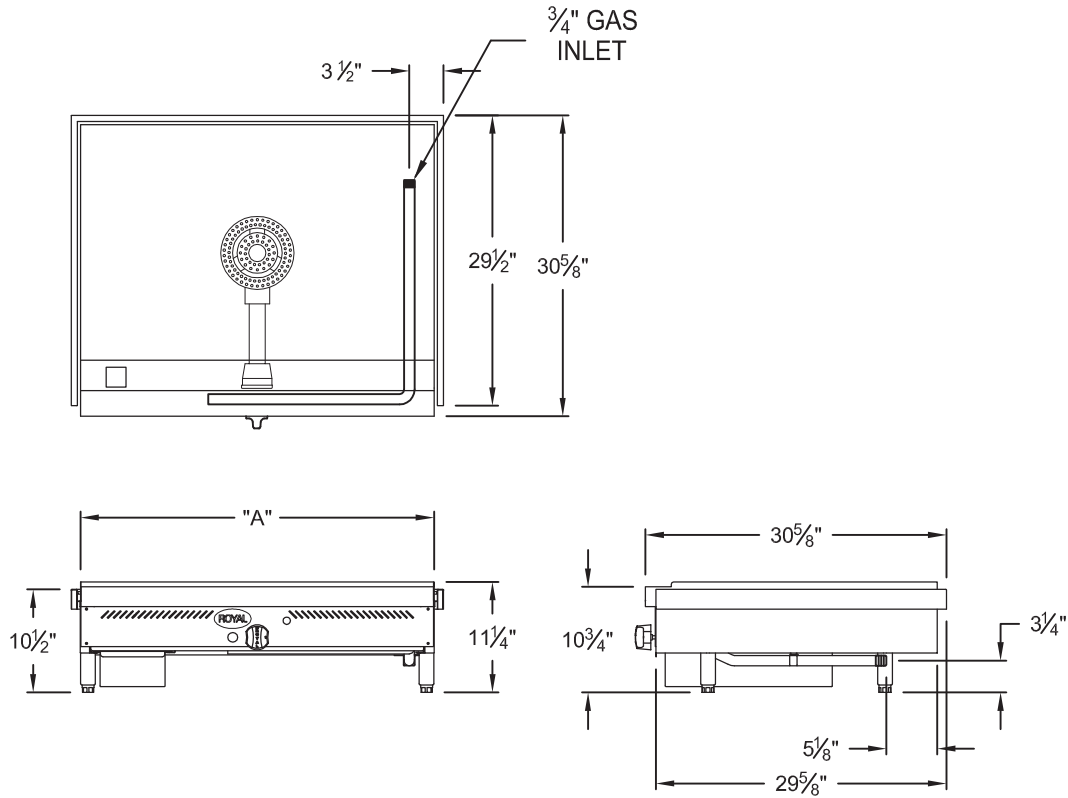

Model Number	Width (A)	Total BTU	Ship Weight
RTY-24	24"	33,000	235 lbs.
RTY-36	36"	33,000	315 lbs.
RTY-48	48"	33,000	395 lbs.
RTY-60	60"	33,000	475 lbs.

### Gas Connection:

3/4" NPT on the right hand rear of the appliance.

The pressure regulator (supplied) is to be connected by the installer.

### Gas Pressure:

5" W.C.	Natural Gas
10" W.C.	Propane

**Clearances:** For installation in non combustible counter only

	Combustible	Non-Combustible
Rear	N/A	0"
Sides	N/A	0"

Specify type of gas and altitude, if over 2,000 feet, when ordering.

Due to continuing product development to ensure best possible performance, these specifications are subject to change without prior notification.

**Royal Range of California**  
 3245 Corridor Dr. • Eastvale, CA 91752 • (800) 769-2414 • (951) 360-1600  
 Fax: (951) 360-7500 • www.royalranges.com • sales@royalranges.com