



Item: _____

Quantity: _____

Project: _____

MANUAL GRIDDLE/ OVER-FIRED BROILER

Delux Series

Models: GB-24 GB-36 GB-48



GB-36

Gas Type: Natural LP

Elevation (if above 2000 ft.): _____

Standard Features

- Fully welded frame with lifetime warranty
- 1,200°F mineral wool insulation
- Stainless steel front and sides
- 10,000 BTU/hr cast burner with heat-radiating stainless steel mesh
- Full width, removable stainless steel crumb pan for easy cleaning
- 3/4" thick griddle plate with polished cooking surface
- Three position pull out broiler rack
- Standing pilots for instant safe ignition
- Easy loading and unloading with a roll-out carriage
- 4" high adjustable heavy duty legs included



LIMITED WARRANTY, TWO YEAR PARTS AND ONE YEAR LABOR

MANUAL GRIDDLE/ OVER-FIRED BROILER

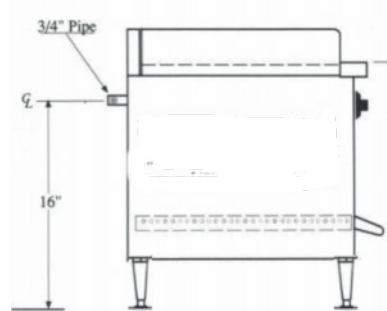
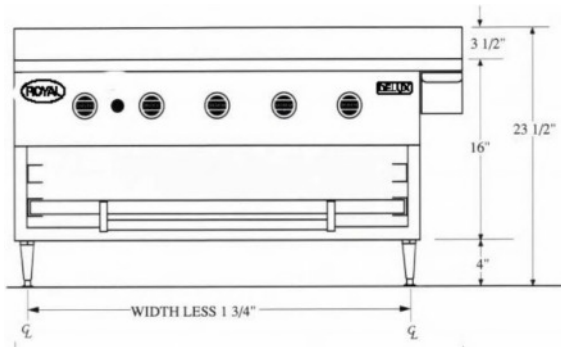
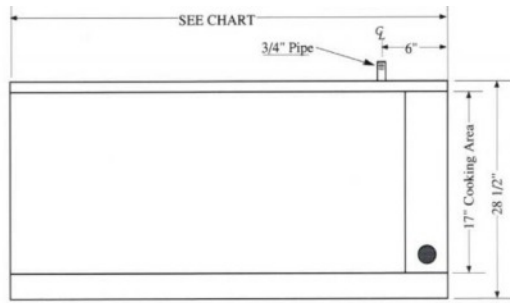

Model Number	Width (A)	Number of Burners	Total BTU	Ship Weight
GB-24	28"	3	30,000	200 lbs.
GB-36	40"	5	50,000	280 lbs.
GB-48	52"	7	70,000	394 lbs.

Notes:

- 1.

Gas Connection:

3/4" NPT on the right hand rear of the appliance.

The pressure regulator (supplied) is to be connected by the installer.

Gas Pressure:

5" W.C.	Natural Gas
10" W.C.	Propane

Clearances:

	Combustible	Non-Combustible
Rear	4"	0"
Sides	4"	0"

Specify type of gas and altitude, if over 2,000 feet, when ordering.

Due to continuing product development to ensure best possible performance, these specifications are subject to change without prior notification.

Royal Range of California

3245 Corridor Dr. • Eastvale, CA 91752 • (800) 769-2414 • (951) 360-1600

Fax: (951) 360-7500 • www.royalranges.com • sales@royalranges.com