



Item: \_\_\_\_\_

Quantity: \_\_\_\_\_

Project: \_\_\_\_\_

## ***Delux Series***

Models:  RPF-50



RPF-50

### **Standard Features**

- 50-80 lb oil capacity
- 8 gpm filter pump for fast filtering
- 5' flush hose & nozzle assembly (wand)
- All stainless steel filter pan assembly with crumb catch basket
- 2" swivel casters (set of four)
- Two year limited warranty, parts and labor

### **Options and Accessories**

- Stainless steel pan cover
- Filter Paper- Item #2768



**LIMITED WARRANTY, TWO YEAR PARTS AND ONE YEAR LABOR**

# Portable Oil Filter

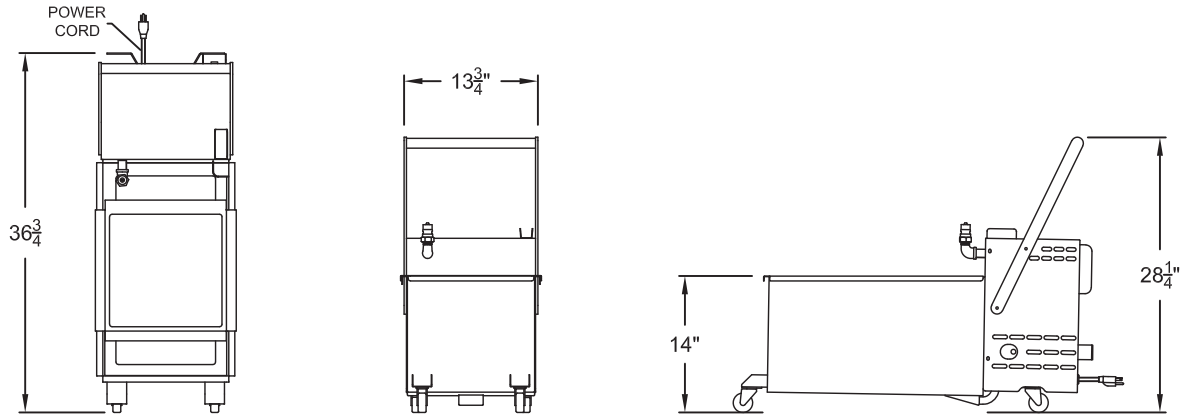

Model Number	Width "A"	Depth "B"	Gallons Per minute	Ship Weight
RPF-50	13- <sup>3</sup> / <sub>4</sub> "	36- <sup>3</sup> / <sub>4</sub> "	8	98 lbs.

## Filter Electrical Requirements, 50/60 Hz:

Volt / Phase	Amps
115V, 1PH	7

Due to continuing product development to ensure best possible performance, these specifications are subject to change without prior notification.

**Royal Range of California**  
 3245 Corridor Dr. • Eastvale, CA 91752 • (800) 769-2414 • (951) 360-1600  
 Fax: (951) 360-7500 • [www.royalranges.com](http://www.royalranges.com) • [sales@royalranges.com](mailto:sales@royalranges.com)