



Item: \_\_\_\_\_

Quantity: \_\_\_\_\_

Project: \_\_\_\_\_

24" Electric Restaurant Range

## Electric Series

Models:  RRE-4     RRE-2GT12     RRE-GT24



RRE-24

Voltage:  208V     240V  
Phase:  1 Phase     3 Phase

### Standard Features

- Stainless steel front, sides, control panel and kick plate including backguard and high shelf
- Stainless steel full width drip tray
- Oven with 4 KW heating element which is completely covered to protect against damage
- Oven thermostat controls, 200°-500°F
- Five position heavy gauge chrome rack guides
- One chrome rack per oven
- Five surface porcelain oven interior
- 9" solid hot plate elements, 2KW each
- GT Series- 3/4 thick polished steel griddle plate
- GT Series - standard with thermostat every 12"
- "Always Operational" with three internal circuit breakers to help prevent the unit from never being completely down

### Options and Accessories

- 6" high S/S stub back in lieu of high shelf
- 1" thick griddle plate
- Griddle on right (Left hand side standard)
- Chrome griddle plate
- Grooved griddle (specify width: \_\_\_\_\_")
- 9" deep S/S front landing ledge, with or without sauce pan cutouts
- Additional oven racks
- Open storage cabinet base - add suffix "-XB"
- Cabinet doors
- Intermediate shelf
- 5" swivel casters (set of four - 2 locking)



**LIMITED WARRANTY, TWO YEAR PARTS AND ONE YEAR LABOR**

# 24" Electric Restaurant Range

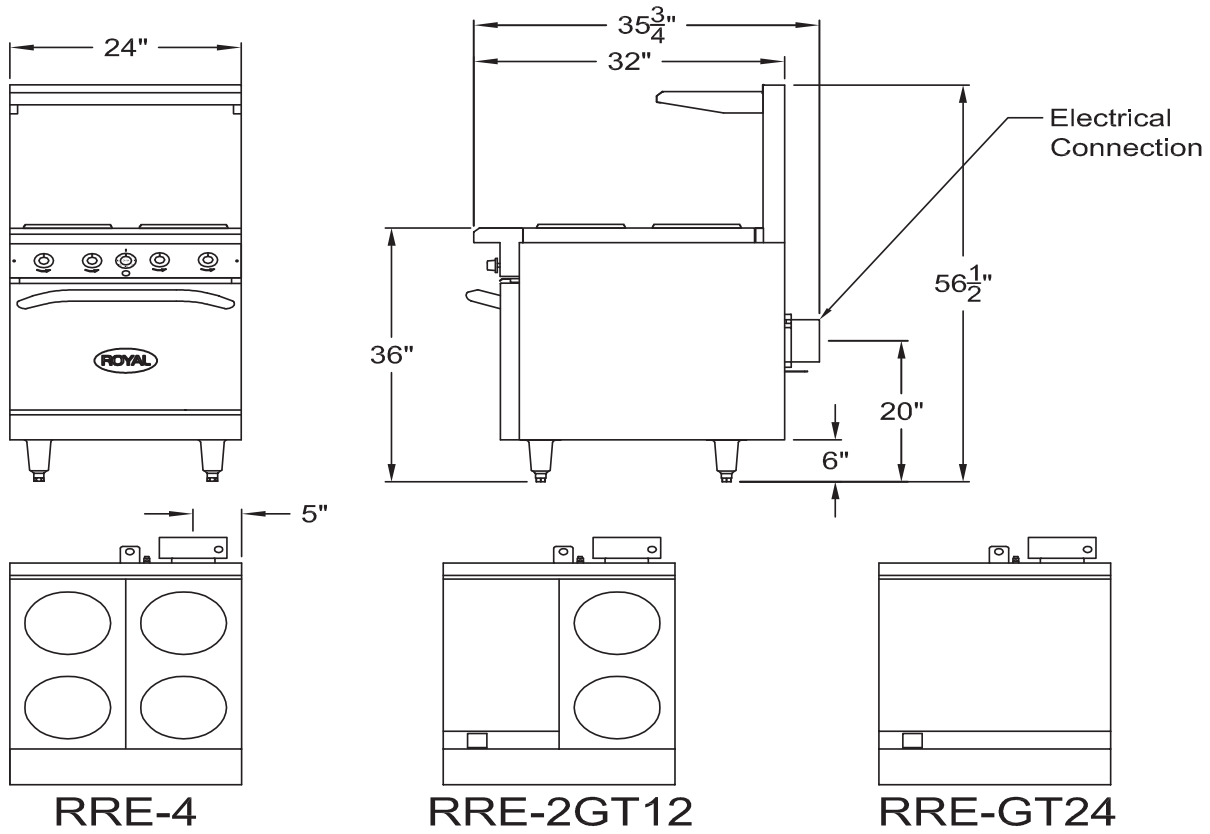

Model	Total KW	Voltage	MAX AMPS		Ship Wt.
			1 Phase	3 Phase	
RRE-4	12	208	58	34	400
		240	50	29	
RRE-2GT12	11.4	208	55	32	420
		240	48	28	
RRE-GT24	10.8	208	52	30	440
		240	45	26	

To be installed only in noncombustible surroundings. See installation instructions.

Due to continuing product development to ensure best possible performance, these specifications are subject to change without prior notification.

**Royal Range of California**  
 3245 Corridor Dr. • Eastvale, CA 91752 • (800) 769-2414 • (951) 360-1600  
 Fax: (951) 360-7500 • www.royalranges.com • sales@royalranges.com