



Item: _____

Quantity: _____

Project: _____

Royal Series

Models: RPC-14



RPC-14

Gas Type: Natural LP

Elevation (if above 2000 ft.): _____

Standard Features

- All 316 stainless steel tank assembly
- Heavy gauge stainless steel base
- All stainless steel front and sides
- 6 individual stainless steel baskets
- Easy to use front mounted water control valve
- 12 Gallon capacity
- Front over flow keeps water clean and starch free
- Cast iron burners rated at 26,000 BTU/hr each
- Millivolt control system with 100% safety shut off
- Thermostatic control with 150°-250° F range adjustable in 10° increments for better heat control.
- 1¼" full port drain valve
- 6" high adjustable heavy duty legs
- Five year limited (prorated) warranty on S/S tank

Options and Accessories

- Stainless steel tank cover
- Stainless steel side splash guard
- Stainless steel joiner strip
- Full pot stainless steel basket for bulk cooking
- 48" quick disconnect and restraining cable
- 5" swivel casters (set of four - 2 locking)



LIMITED WARRANTY, TWO YEAR PARTS AND ONE YEAR LABOR

Pasta Cooker

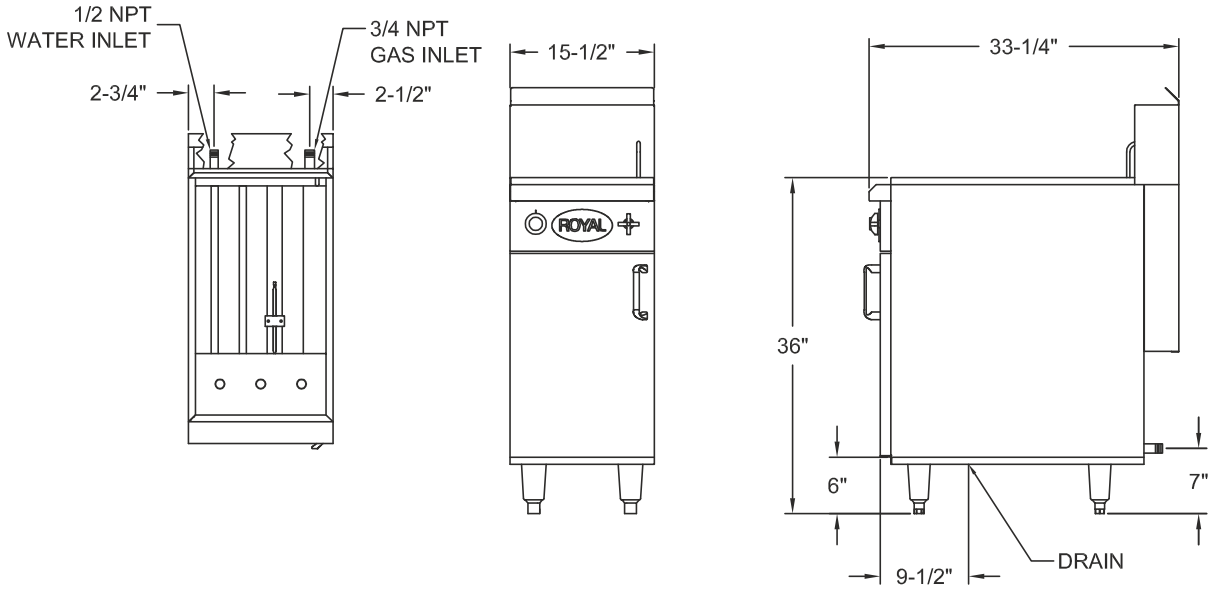

Model Number	Cooking Area	Number of Burners	Total BTU	Ship Weight
RPC-14	14" x 18"	3	78,000	210 lbs.

Notes:

- Burner rated at 26,000 BTU/hr each

Gas Connection:

3/4" NPT on rear of the appliance.
No external pressure regulator required.

Water Connection:

1/2" NPT on rear of the appliance.

Drain connection:

1-1/4" NPT

Gas Pressure:

4" W.C.	Natural Gas
11" W.C.	Propane

Clearances:

	Combustible	Non-Combustible
Rear	6"	0"
Sides	6"	0"

Specify type of gas and altitude, if over 2,000 feet, when ordering.

Due to continuing product development to ensure best possible performance, these specifications are subject to change without prior notification.

Royal Range of California
 3245 Corridor Dr. • Eastvale, CA 91752 • (800) 769-2414 • (951) 360-1600
 Fax: (951) 360-7500 • www.royalranges.com • sales@royalranges.com