



Item: _____

Quantity: _____

Project: _____

Kabob Broiler

Royal Series

Models: RKTB-24 RKTB-30 RKTB-36 RKTB-48 RKTB-60
 RKTB-72 RKTB-84



RKTB-36

Gas Type: Natural LP

Elevation (if above 2000 ft.): _____

Standard Features

- Low Profile
- Easily removable and replaceable independent firebox assembly
- Large capacity removable stainless steel water pan under the broiler for easy cleaning
- Stainless Steel radiant covers
- Welded and insulated heavy gauge chassis for long life
- Stainless steel sides, front valve cover and ledge
- Double wall panels for cooler sides
- All welded fire box supports heavy duty radiant covers
- Stainless steel tubular burners rated at 18,000 BTU/hr each
- Individually adjustable burners provide powerful radiant heat
- Standing pilots for instant ignition
- Stainless steel tubing for pilots
- 4" high adjustable heavy duty legs included

Options and Accessories

- Add plate shelf with or without cutouts
- Stainless Steel Equipment Stand
 - Knock Down All Welded
- Size
- 24" 30" 36" 48" 60" 72" 84"
- 5" swivel casters (set of four - 2 locking)
- 5" swivel casters (set of six - 3 locking) (60", 72" and 84" models)



LIMITED WARRANTY, TWO YEAR PARTS AND ONE YEAR LABOR

Kabob Broiler

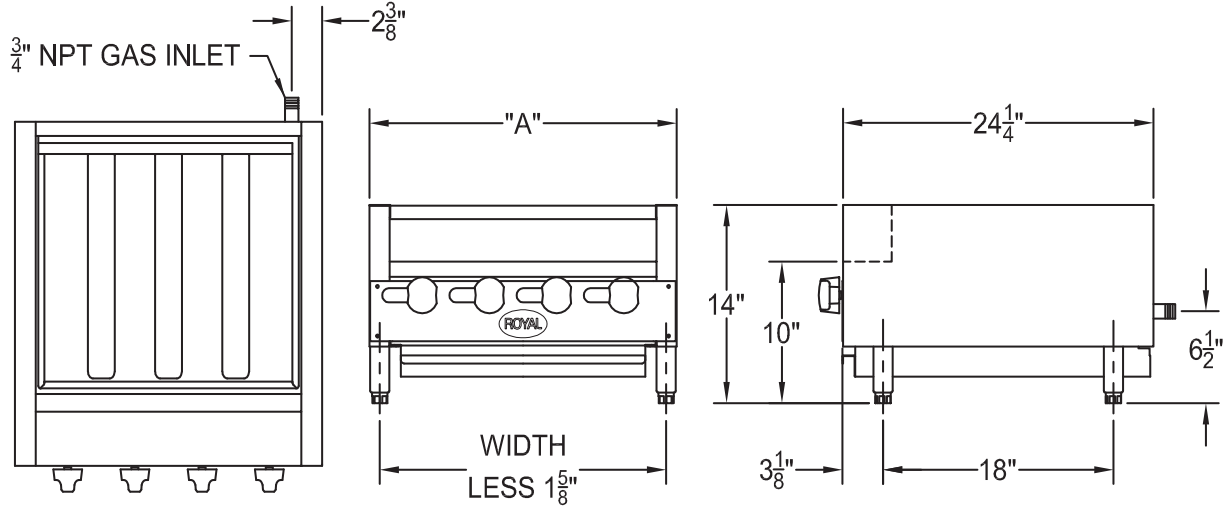

Model Number	Width (A)	Number of Burners	Total BTU	Ship Weight
RKTB-24	25-1/2"	4	72,000	260 lbs.
RKTB-30	31"	5	90,000	305 lbs.
RKTB-36	36"	6	108,000	350 lbs.
RKTB-48	48"	8	144,000	405 lbs.
RKTB-60	60"	10	180,000	455 lbs.
RKTB-72	72"	12	216,000	510 lbs.
RKTB-84	84"	14	252,000	570 lbs.

Notes:

- Each burner is rated at 18,000 BTU/hr

Gas Connection:

3/4" NPT on the right hand rear of the appliance.

The pressure regulator (supplied) is to be connected by the installer.

Specify type of gas and altitude, if over 2,000 feet, when ordering.

Gas Pressure:

5" W.C.	Natural Gas
10" W.C.	Propane

Clearances:

	Combustible	Non-Combustible
Rear	4"	0"
Sides	15"	0"

Due to continuing product development to ensure best possible performance, these specifications are subject to change without prior notification.

Royal Range of California

3245 Corridor Dr. • Eastvale, CA 91752 • (800) 769-2414 • (951) 360-1600
 Fax: (951) 360-7500 • www.royalranges.com • sales@royalranges.com