



Item: _____

Quantity: _____

Project: _____

50 lb. / 25 lb. Deep Fat Fryer

Royal Series

Models: RFT-5025 RFT-2550



RFT-5025 with optional casters

Gas Type: Natural LP

Elevation (if above 2000 ft.): _____

Options and Accessories

- Stainless steel tank cover
- Stainless steel side splash guard
- Stainless steel joiner strip
- 8" welded front plate shelf
- 48" quick disconnect and restraining cable
- 5" swivel casters (set of four - 2 locking)

Standard Features

- All stainless steel front and sides
- (1) 50 lb capacity stainless steel tank assembly
- 14" x 14" frying area
- (1) 25 lb capacity stainless steel tank assembly
- 6 3/4" x 14" frying area
- Cast iron burners rated at 38,000 BTU/hr each
- Millivolt control system with 100% safety shut off
- Thermostatic control with 200°-400° F range
- Two fry baskets with plastic coated handles for ease of handling
- 1 1/4" full port drain valve per tank
- 6" high adjustable heavy duty legs
- One year limited warranty, parts and labor
- Five year limited (prorated) warranty on S/S tank



50 lb. / 25 lb. Deep Fat Fryer

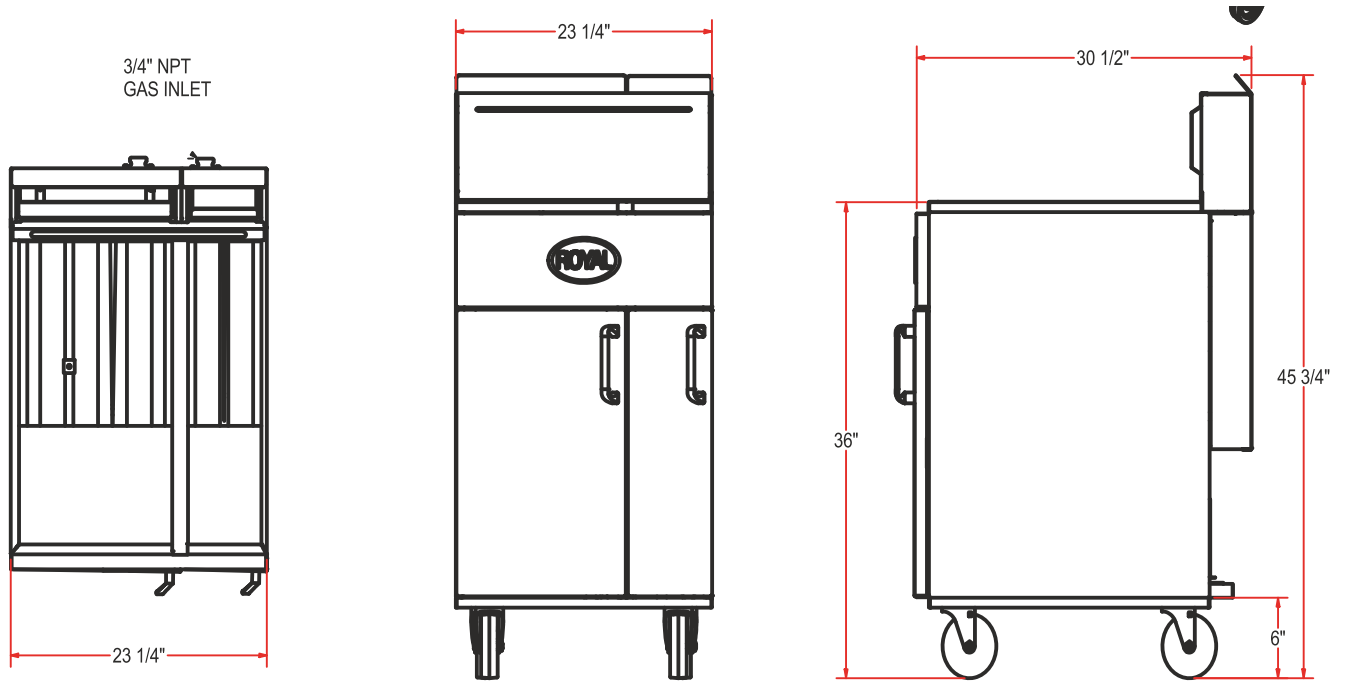

Model Number	(1) Cooking Area	(1) Cooking Area	Number of Burners	Total BTU	Ship Weight
RFT-5025	14" x 14"	6 3/4" x 14"	50 lb. (3), 25 lb. (2)	190,000	260 lbs.
RFT-2550	6 3/4" x 14"	14" x 14"	25 lb. (2), 50 lb. (3)	190,000	260 lbs.

Notes:

- Burner rated at 38,000 BTU/hr each

Gas Connection:

Two 3/4" NPT .

No external pressure regulator required.

Gas Pressure:

4" W.C.	Natural Gas
11" W.C.	Propane

Clearances:

	Combustible	Non-Combustible
Rear	6"	0"
Sides	6"	0"

Specify type of gas and altitude, if over 2,000 feet, when ordering.

Due to continuing product development to ensure best possible performance, these specifications are subject to change without prior notification.

Royal Range of California

3245 Corridor Dr. • Eastvale, CA 91752 • (800) 769-2414 • (951) 360-1600

Fax: (951) 360-7500 • www.royalranges.com • sales@royalranges.com