



Item: \_\_\_\_\_

Quantity: \_\_\_\_\_

Project: \_\_\_\_\_

Radiant Broiler Range

## Royal Series

Models:  RR-24RB-120  
 RR-36RB-XB

RR-24RB-XB  
 RR-48RB-126

RR-36RB-126



RR-36RB-126 with optional casters

Gas Type:  Natural  LP

Elevation (if above 2000 ft.): \_\_\_\_\_

### Standard Features

- Easily removable independent firebox assembly
- Full width, removable stainless steel crumb pan under the broiler for easy cleaning
- Stainless steel sides, front, valve cover and kick plate including backguard without hi-shelf
- Stainless steel tubular burners rated at 15,000 BTU/hr each
- Individually adjustable burners provide powerful radiant heat
- Standing pilots for instant safe ignition
- Heavy duty cast iron top grates
- Stainless Steel Oven "U" shaped burner rated at 27,000 BTU/hr for 20" oven
- Stainless Steel Oven "U" shaped burner rated at 35,000 BTU/hr for 26" oven
- Solid welded heavy gauge metal frame
- Five position heavy gauge chrome rack guides
- One chrome rack per oven
- Five surface porcelain oven interior
- Stainless steel tubing for burners and pilots

### Options and Accessories

- Fish grate
- Diamond grate
- Stainless steel side splash guard, up to 12" high
- 9" deep S/S front landing ledge with or without cutouts
- Extra oven rack
- 6" high S/S stub back in lieu of high back riser
- Convection oven base - add suffix "C" (not available for 24" model)
- Door for open storage area ("-XB" models)
- Shelves for open storage area ("-XB" models)
- 5" swivel casters (set of four - 2 locking)



**LIMITED WARRANTY, TWO YEAR PARTS AND ONE YEAR LABOR**

# Radiant Broiler Range

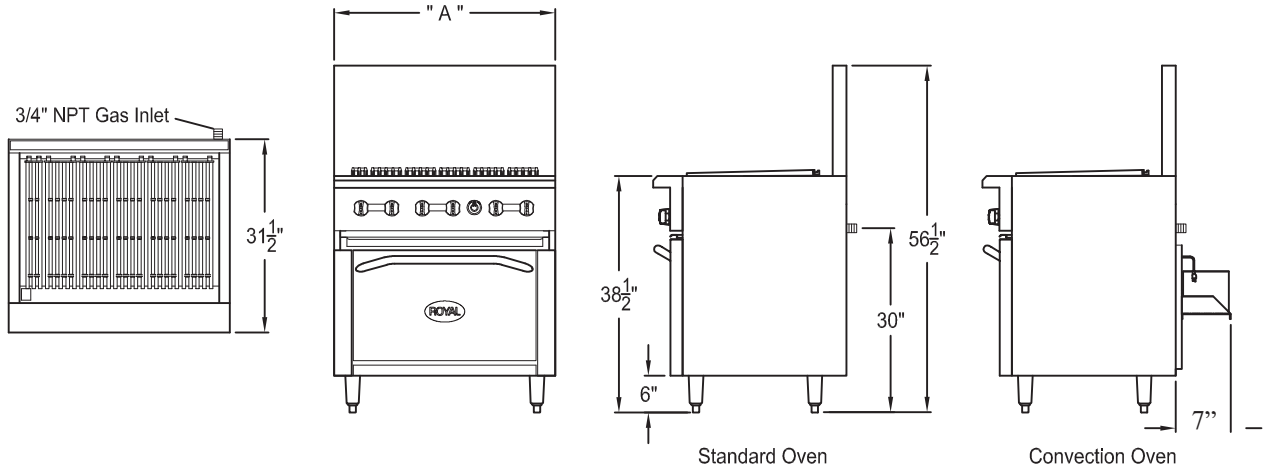

Model Number	Width (A)	Radiant Burners	Oven Burners	Total BTU	Ship Weight
RR-24RB-120	24"	4	1 <sup>1</sup>	87,000	515 lbs.
RR-24RB-XB	24"	4	0	60,000	330 lbs.
RR-36RB-126	36"	6	1 <sup>2</sup>	125,000	635 lbs.
RR-36RB-XB	36"	6	0	90,000	440 lbs.
RR-48RB-126	48"	8	1 <sup>2</sup>	155,000	800 lbs.

**Notes:**

1. 20" wide oven with burner at 27,000 BTU/hr each ("-120")
2. 26½" wide oven with burner at 35,000 BTU/hr each ("-126")
  - Radiant burners at 15,000 BTU/hr
  - "-XB" is an open storage base
  - Convection Oven with burner at 30,000 BTU/hr - add suffix "C" and deduct 5,000 BTU/hr

**Gas Connection:**

3/4" NPT on the right hand rear of the appliance. The pressure regulator (supplied) is to be connected by the installer.

**Gas Pressure:**

5" W.C.	Natural Gas
10" W.C.	Propane

**Clearances:** For installation in non combustible locations only

	Combustible	Non-Combustible
Rear	N/A	0"
Sides	N/A	0"

Specify type of gas and altitude, if over 2,000 feet, when ordering.

Due to continuing product development to ensure best possible performance, these specifications are subject to change without prior notification.

**Royal Range of California**  
 3245 Corridor Dr. • Eastvale, CA 91752 • (800) 769-2414 • (951) 360-1600  
 Fax: (951) 360-7500 • www.royalranges.com • sales@royalranges.com