



Item: _____

Quantity: _____

Project: _____

Electric Series

Models: REF-1417 REF-1421



REF-1417-CM shown with optional casters, lift-up elements and crumb screen

Voltage: 208V 240V
 Phase: 1 Phase 3 Phase

- DM - Digital solid state thermostat
- DM2 - Two channel solid state digital control with melt cycle
- CM - 8 product computer control with individual programming capabilities for temperature and compensating time

Standard Features

- All stainless steel front and sides
- 50 lb capacity stainless steel tank assembly
- Frying Area: 13 5/8" x 14"
- Heavy duty electric elements
- DM- Solid state digital controls
- Thermostatic control with 200°-400° F range
- Twin fry baskets with plastic coated handles for ease of handling
- 1 1/4" full port drain valve
- 6" high adjustable heavy duty legs
- Five year limited (prorated) warranty on S/S tank

Options and Accessories

- DM2 or CM controller
- Stainless steel tank cover
- Stainless steel side splash guard
- Stainless steel joiner strip
- 5" swivel casters (set of four - 2 locking)
- Counter-balanced swing-up heating elements
- Crumb screen with handle



LIMITED WARRANTY, TWO YEAR PARTS AND ONE YEAR LABOR

50 lb. Energy Efficient Electric Deep Fat Fryer

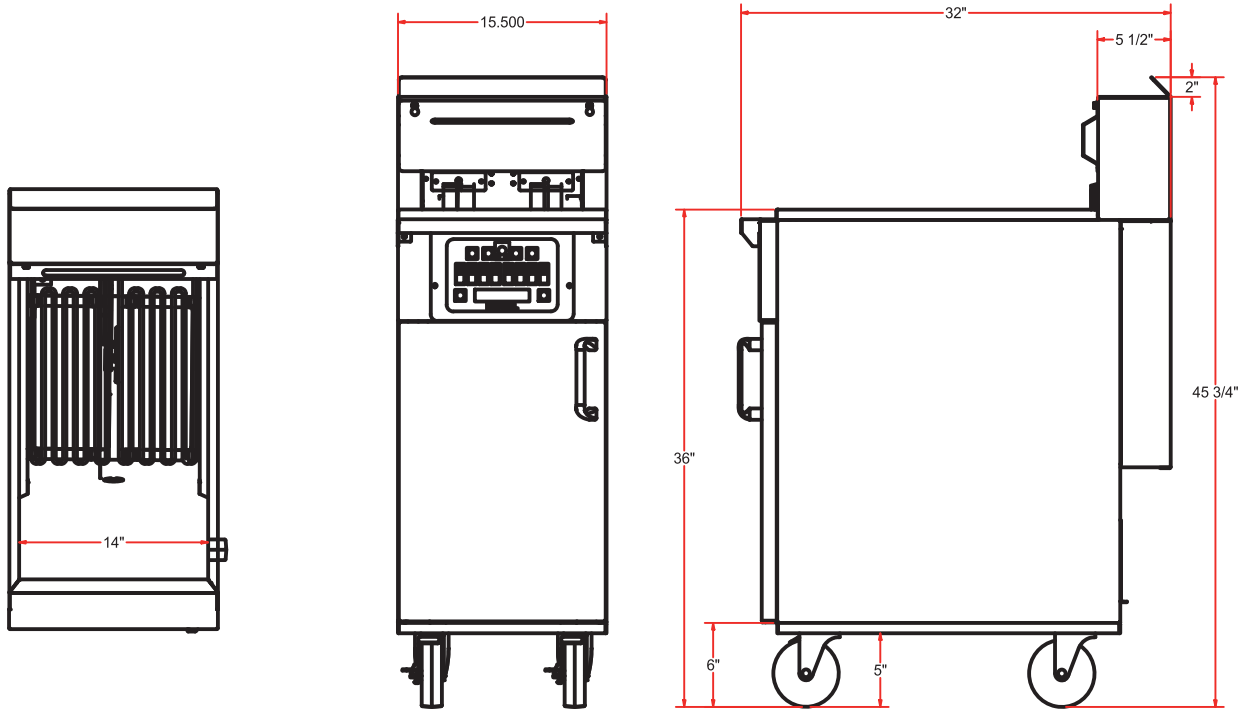

Model Number	Total KW	Voltage	MAX AMPS	Ship Wt.
			3 Phase	
REF-1417	17	208	48	210
		240	41	
REF-1421	21	208	59	210
		240	40	

To be installed only in noncombustible surroundings. See installation instructions.

Due to continuing product development to ensure best possible performance, these specifications are subject to change without prior notification.

Royal Range of California
 3245 Corridor Dr. • Eastvale, CA 91752 • (800) 769-2414 • (951) 360-1600
 Fax: (951) 360-7500 • www.royalranges.com • sales@royalranges.com