



Item: _____

Quantity: _____

Project: _____

Delux Series

Models: RHEF-60-DM RHEF-60-DM2 RHEF-60-CM



**Patent Pending*

RHEF-60-CM, Shown with optional casters

Gas Type: Natural LP

Elevation (if above 2000 ft.): _____

- DM - Digital solid state thermostat
- DM2 - Two channel solid state digital control with melt cycle
- CM - 8 product computer control with individual programming capabilities for temperature and compensating time

Standard Features

- 65% Energy Efficiency
- 95 lbs. Per hour production capacity
- 60 lb capacity stainless steel tank assembly
- 14" X 18" frying area
- All stainless steel cabinet
- Innovative heat exchanger assembly transfers maximum heat to the oil
- 3 tube heat entry with easily removable diffusers reduces thermal stress
- Automatic pilot ignition with 100% safety
- High efficiency in-shot burners rated at 33,000 BTU/hr each
- Extremely low exhaust flue temperatures
- Three fry baskets with plastic coated handles for ease of handling
- 1/4" full port drain valve
- 6" heavy duty adjustable legs
- Ten year limited (prorated) warranty on S/S tank

Options and Accessories

- Stainless steel tank cover
- Stainless steel side splash guard
- Stainless steel joiner strip
- 48" quick disconnect and restraining cable
- 5" swivel casters (set of four - 2 locking)



LIMITED WARRANTY, TWO YEAR PARTS AND ONE YEAR LABOR

60 lb. High Efficiency Deep Fat Fryer

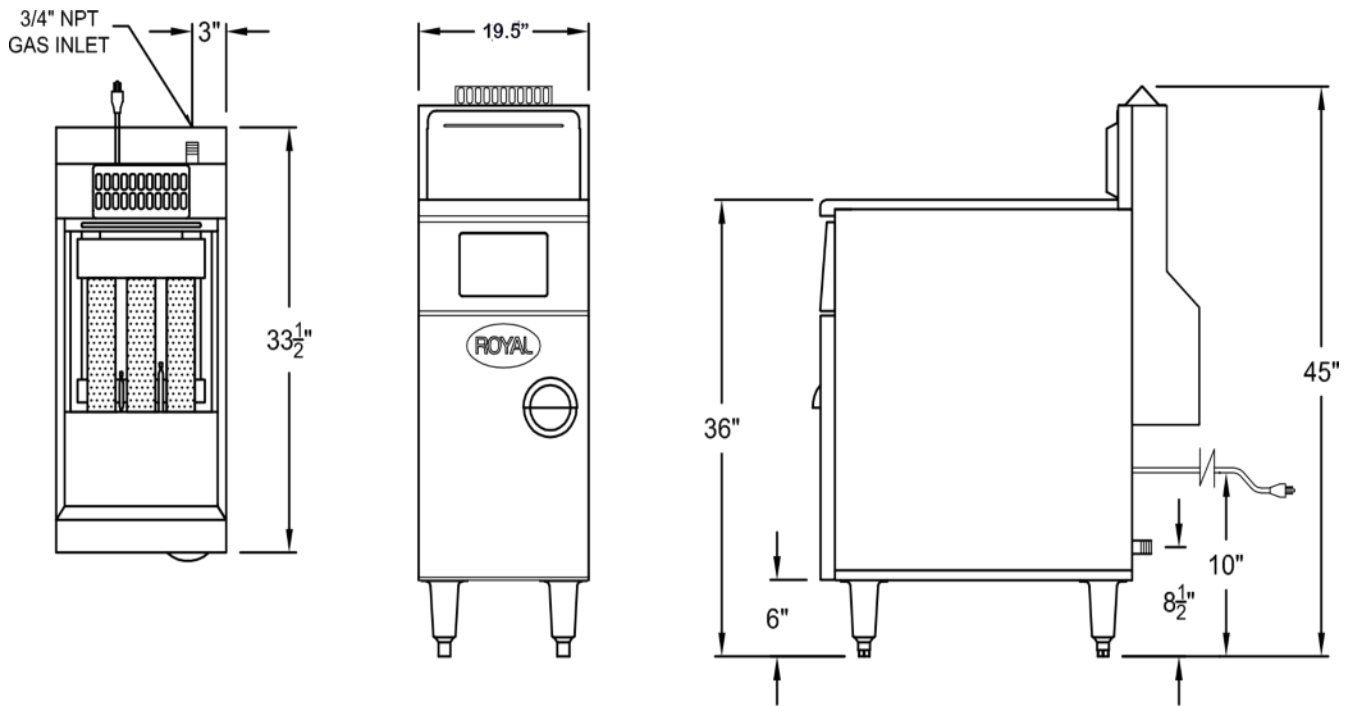

Model Number	Cooking Area	Number of Burners	Total BTU	Ship Weight
RHEF-60-DM RHEF-60-DM2 RHEF-60-CM	14" x 18"	3	99,000	210lbs.

Gas Connection:

3/4" NPT on the right hand rear of the appliance.
No external pressure regulator required.

Gas Pressure:

3.5" W.C.	Natural Gas
10" W.C.	Propane

Electrical:

120V, 60 Hz, 1 Ph, 2 Amps
Provided with 6' power cord fitted with standard
3 prong grounded plug

Clearances:

	Combustible	Non-Combustible
Rear	6"	0"
Sides	6"	0"

Specify type of gas and altitude, if over 2,000 feet, when ordering.

Due to continuing product development to ensure best possible performance, these specifications are subject to change without prior notification.

Royal Range of California

3245 Corridor Dr. • Eastvale, CA 91752 • (800) 769-2414 • (951) 360-1600
Fax: (951) 360-7500 • www.royalranges.com • sales@royalranges.com