

Restaurant Ranges with Oven

OPEN BURNERS WITH OVEN



BUILT TO LAST, ENGINEERED FOR EXCELLENCE

The Asber 'Emerald' Series Commercial Ranges are built for high-volume kitchens demanding versatility, durability, and power. With heavy-duty stainless-steel construction, they deliver consistent performance and energy efficiency. Their standout features—an innovative cooktop and industry-leading oven capacity—make them the ideal centerpiece for any demanding operation.

COOKING SURFACE

- 26-inch-deep cooking area with a 14-inch rear section designed to handle large stock pots and high-capacity cookware.
 - Front heavy-duty cast iron grates: 12" x 12".
 - Rear heavy-duty cast iron grates: 12" x 14".
- The only range top in its class that efficiently transfers heat to the rear burners—maximizing usable surface area and accelerating cooking times.
- Competing models may feature rear burners, but only Asber's grate design ensures even heat distribution and superior thermal performance.

OVEN FEATURES

- Offers the largest oven capacity in the industry, accommodating up to 5 racks at once—ideal for batch cooking, roasting, or baking.
- 36" Range: Chef-depth+ oven interior easily fits two full-size turkeys:
 - (1) 18" x 26" full-size sheet pan.
 - (1) 12" x 20" foodservice pan side-by-side (L/R) (F/B).
- 24" Range: chef-depth oven interior fits: (1) 18" x 26" sheet pan front-to-back (F/B).
- Stainless-steel 'U'-shaped burner, rated at 30,000 BTU, provides rapid preheat and quick temperature recovery.
- Adjustable temperature range: 250°F to 500°F, allowing everything from slow roasting to high-heat baking.
- Includes one heavy-duty oven rack standard.

HIGH PERFORMANCE OPEN BURNERS

- 'Crown'-type cast iron burners, each delivering 30,000 BTU of powerful, even heat.
- Anti-clog, lift-off design simplifies cleaning and ensures long-term reliability.

- Stainless-steel burner supports and pilot tubing for durability and easy service.
- Stamped inner components reinforce structural integrity and ensure long-term reliability in high-use environments.
- Manual ignition with independently controlled stainless-steel standing pilot lights provides precise heat management—ideal for preparing multiple items at once.

PREMIUM CONSTRUCTION

- Stainless steel front, sides, landing ledge, and backsplash for durability and easy cleaning.
- Fully insulated front, sides, back, top, and oven door to maintain consistent heat and reduce energy use.
- Porcelain-coated oven floor and back door resists stains and allows easy cleaning.
- Stamped inner door lining reinforces structural integrity.
- Counterbalanced, self-leveling door ensures smooth operation and can be easily detached for cleaning or service.
- 14-gauge stainless-steel hotplate 'U'-frame provides strength and durability for heavy-duty use.
- 1-inch-deep, full-length, removable stainless-steel grease tray simplifies maintenance and cleanup.

OPERATOR-FOCUSED DESIGN

- Zamak flame control knobs for precise heat adjustment and a solid, professional feel.
- Standard gas regulator ensures safe and consistent gas flow.
- Gas conversion kit included for easy switching between NG and LPG.
- Large 6-inch stainless-steel landing ledge provides ample workspace for plating and prep.
- Adjustable stainless-steel legs (6"–8") provide stable, level installation on uneven surfaces.

OPTIONS & ACCESSORIES

- Salamander/Cheese Melter landing shelf.
- Set of 4 heavy-duty casters (2 with brakes).
- Additional oven racks.



AER 4 24 EM



AER 6 36 EM

MODEL	OVEN (BTU)	HOTPLATE (BTU)	TOTAL BTU	EXTERIOR DIMENSIONS (in)			SHIPPING	
				Width	Depth	Height	Lbs	ft ³
OPEN BURNERS WITH OVEN								
AER 4 24 EM	30.000	120.000	150.000	24	34	56-1/8	357	24.7
AER 6 36 EM	30.000	180.000	210.000	36	34	56-1/8	434	35.3

SPECIFICATIONS ARE SUBJECT TO CHANGE WITHOUT PRIOR NOTICE. | SPECIFICATIONS VALID ONLY FOR CONTINENTAL USA & CANADA.

Restaurant Ranges with Oven

OPEN BURNERS WITH OVEN



AER 4 24 EM

AER 6 36 EM

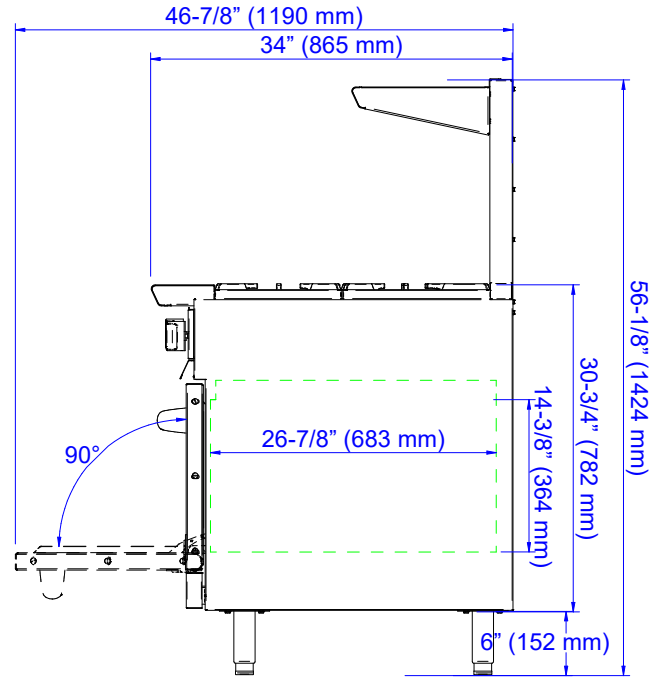
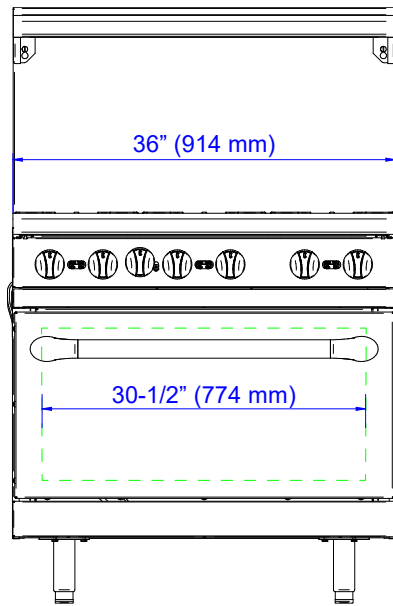
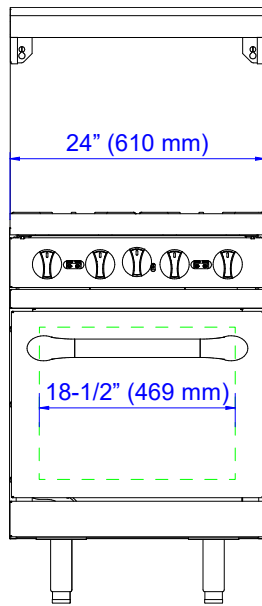

MODEL	AER 4 24 EM	AER 6 36 EM
GAS CONNECTION		
Gas Type	NG / LPG	
Gas Pressure	5" W.C. / 10" W.C.	
Gas Line	Ø 3/4" (at least)	
INTERIOR DIMENSIONS (in)		
Width	18-5/8	30-1/2
Depth	26-7/8	
Height	14-3/8	
Shelf (in)	13-5/8 x 22	29-7/8 x 24-3/8
SHIPPING DIMENSIONS (in)		
Width	27-1/2	39
Depth	36-1/4	
Height	41-3/8	



INSTALLATION REQUIREMENTS

- 1. GAS PRESSURE:** a pressure regulator sized for this unit is included, to be installed at the time of connection.
- 2. GAS CONNECTION:** gas line must be 3/4" or larger, same if flexible connectors are used.
- 3. VENTILATION:** an adequate ventilation system is required for commercial cooking equipment. Request more info @ National-Fire Protection Association, www. NFPA.org.
- 4. CLEARANCE:** 3" on the sides and the back for combustible; 0" for non-combustible buildings.
- 5. CERTIFICATION FOR COMMERCIAL USE:** The equipment listed in this spec sheet is certified and approved for commercial use, complying with food safety and sanitation standards for commercial applications.

SPECIFICATIONS ARE SUBJECT TO CHANGE WITHOUT PRIOR NOTICE. | SPECIFICATIONS VALID ONLY FOR CONTINENTAL USA & CANADA.